

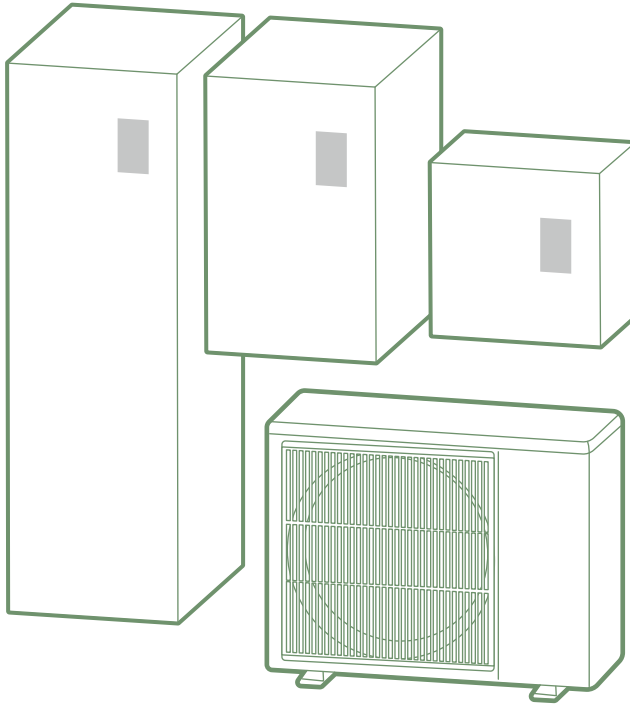

U0801160_4001_ML_1
25/11/2025



ML

Maintenance

Wartung // Onderhoud // Manutenzione // Mantenimiento // Manutenção //
Konservacja // Hooldus // Údržba // Priežiūra // Vzdrževanje // Συντήρηση //
Održavanje // Huolto // Underhåll // Vedligeholdelse // Karbantartás // Vedlikehold //
Поддръжка // Bakım

Destinée au professionnel. À conserver par l'utilisateur pour consultation ultérieure

FR Cette notice traite de l'entretien de l'appareil de façon générique, sans prise en compte de modèle particulier.

Les étapes d'entretien sont à adapter selon le modèle et la réglementation locale.

EN This manual deals with the general maintenance of the appliance, and is not specific to any particular model.

The maintenance steps are to be adapted to suit the model and local regulations.

DE Diese Anleitung beschreibt die Geräterwartung im Allgemeinen, ohne auf ein bestimmtes Modell näher einzugehen.

Die Wartungsschritte sind dem Gerätemodell und den örtlichen Bestimmungen anzupassen.

NL Deze handleiding behandelt het onderhoud van de apparaten in het algemeen, geen modellen in het bijzonder.

De onderhoudsfasen worden aangepast aan het model en aan de lokale regelgeving.

IT Il presente manuale descrive gli interventi di manutenzione dell'apparecchio in maniera generica, senza tenere conto del modello specifico.

Le fasi di manutenzione vanno adattate in base al modello e alla regolamentazione locale.

ES Este manual trata el mantenimiento del aparato en general, sin tener en cuenta ningún modelo en particular.

Los pasos de mantenimiento deben adaptarse según el modelo y la normativa locales.

PT Este manual trata da conservação do aparelho de maneira genérica, sem tomar em conta um modelo particular.

As etapas de conservação devem ser adaptadas conforme o modelo e a regulamentação local.

PL Niniejsza instrukcja dotyczy konserwacji urządzenia w ujęciu ogólnym, bez uwzględnienia konkretnego modelu.

Etapy konserwacji należy dostosować do modelu i miejscowych przepisów.

ET Selles juhendis käsitletakse seadme üldist hooldust, pidamata silmas ühtegi konkreetset mudelit.

Hooldustoimingud tuleb kohandada vastavalt mudelile ja kohalikele eeskirjadele.

CZ Tento návod se týká údržby spotřebiče obecně bez ohledu na konkrétní model.

Jednotlivé kroky údržby je třeba přizpůsobit modelu a místním předpisům.

LT Šioje naudojimo instrukcijoje bendrai aptariama prietaiso priežiūra, neatsižvelgiant į konkretų modelį.

Priežiūros etapus reikia pritaikyti konkrečiam modeliui, atsižvelgiant į vietos teisės aktų reikalavimus.

SL V tem priročniku so navodila za splošno vzdrževanje naprav, pri čemer niso upoštewane posebnosti modela.

Navodila za vzdrževanje je treba prilagoditi posebnostim modela in lokalnim predpisom.

EL Tento návod se týká údržby spotřebiče obecně bez ohledu na konkrétní model.

Jednotlivé kroky údržby je třeba přizpůsobit modelu a místním předpisům.

- SR** Ovo obaveštenje tiče se generičkog održavanja aparata, bez uzimanja u obzir nekog posebnog modela.
Faze održavanja treba da se prilagode zavisno od modela i lokalne regulative.
- FI** Tässä ohjeessa esitellään laitteen huolto yleisesti ottamatta huomioon tiettyä mallia.
Huoltovaiheet on mukautettava mallin ja paikallisten säännösten mukaisesti.
- SV** Denna bruksanvisning behandlar service av apparaten generellt, utan att ta hänsyn till specifik modell.
Servicearbetena ska anpassas beroende på modell och lokala bestämmelser.
- SK** Tento návod sa zaoberá všeobecnou údržbou zariadenia bez ohľadu na akýkoľvek konkrétny model.
Kroky údržby je potrebné prispôbiť modelu a miestnym predpisom.
- DA** Denne vejledning omhandler vedligeholdelse af apparatet generelt, uden at tage hensyn til en bestemt model.
Vedligeholdelsesforløbet skal tilpasses efter modellen og de lokale bestemmelser.
- HU** Ez a kézikönyv a készülék általános karbantartásával foglalkozik, anélkül, hogy egy adott modellre utalna.
A karbantartási szakaszt a modellhez és a helyi előírásokhoz kell igazítani.
- NO** Denne håndboken tar for seg vedlikehold av enheten på en generell måte, uten å ta hensyn til noen spesiell modell.
Vedlikeholdstrinnene skal tilpasses i henhold til modell og lokale forskrifter.
- HR** Ovaj se priručnik bavi održavanjem uređaja na generički način, bez uzimanja u obzir bilo kojeg posebnog modela.
Koraci održavanja moraju se prilagoditi prema modelu i lokalnim propisima.
- BG** Настоящото ръководство разглежда поддръжката на уреда по общ начин, без да взема предвид конкретен модел.
Стъпките за поддръжка трябва да се адаптират в зависимост от модела и местните разпоредби.
- TR** Bu kılavuz, herhangi bir özel modeli dikkate almadan, cihazın bakımını genel bir şekilde ele almaktadır.
Bakım aşamaları modele ve yerel yönetmeliklere göre uyarlanmalıdır.

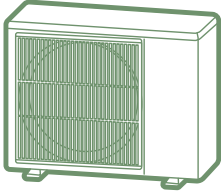

ESD

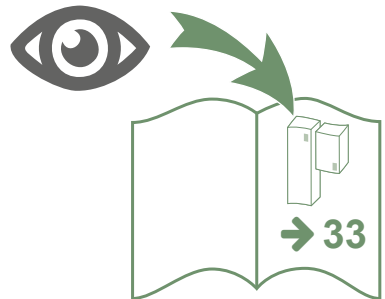
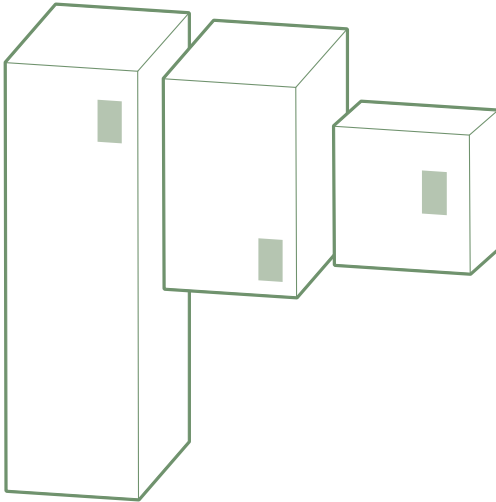
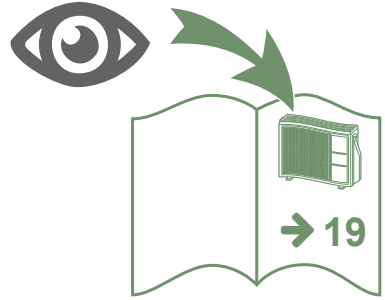
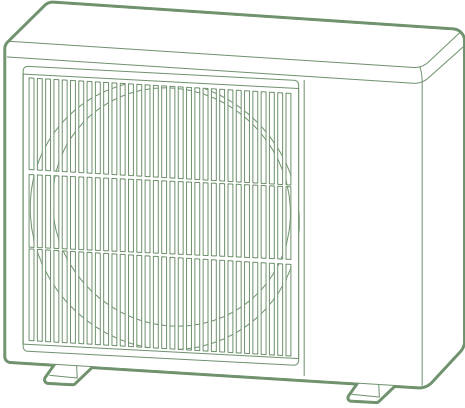

■ Conditions d'entretien

L'entretien de l'appareil doit être effectué par un professionnel agréé conformément aux textes réglementaires et règles de l'art en vigueur notamment :

- Decret 2020-912 du 28 juillet 2020 et ses arrêtés d'application relatifs à l'inspection et à l'entretien des chaudières, des systèmes de chauffages et des systèmes de climatisation



Toute modification ou intervention sur l'appareil non autorisée par le fabricant entraînera systématiquement une suppression de la garantie.

Avant toute intervention, s'assurer que toutes les alimentations électriques sont coupées.

L'installation électrique doit être réalisée conformément à la réglementation en vigueur (norme NF C 15-100 - France).

Énergie stockée : après sectionnement des alimentations attendre 10 minutes avant d'accéder aux parties internes de l'équipement.



Les équipements de protection individuelle sont correctement utilisés.



Lire la notice d'installation



Lire les instructions

■ Maintenance Requirements

The appliance must be maintained by an approved professional in accordance with current regulations and codes of practice.



Any modification or work on the device not authorised by the manufacturer will automatically void the warranty.



Before performing any maintenance, make sure that all power supplies have been isolated.

Stored energy: To allow safe discharge after cutting off the power supplies, wait for 10 minutes before accessing the internal parts of the equipment.



Ensure personal protective equipment is being used correctly



Read the installation manual



Read the Installation and Operating Manuals

■ Wartungsvorschriften

Die Installation Instandhaltung des Geräts müssen einem zugelassenen Fachmann gemäß den einschlägigen Vorschriften und dem Stand der Technik anvertraut werden.



Jegliche Modifikation oder Eingriffe am Gerät, die nicht vom Hersteller autorisiert sind, führen automatisch zum Erlöschen der Garantie.



Vor jeglichem Eingriff muss sichergestellt werden, dass alle Stromversorgungen abgeschaltet sind.

Gespeicherte Energie: nach dem Abschalten der Stromversorgungen 10 Minuten warten, bevor auf die internen Teile des Gerätes zugegriffen wird.



Die persönliche Schutzausrüstung ist wird richtig verwendet.



Die Installationsanleitung lesen



Die Anweisungen lesen

■ Onderhoudsvoorschriften

Het apparaat dient onderhouden te worden door een gekwalificeerde vakman, volgens de geldende regelgeving en installatievoorschriften.



Elke wijziging of ingreep aan het apparaat die niet door de fabrikant wordt voorgeschreven leidt tot het vervallen van de garantie.



Voor iedere vorm van onderhoud dient de elektrische voeding uitgeschakeld te worden.



Opgeslagen energie: na het afkoppelen van de elektrische voeding geldt een wachttijd van 10 minuten voordat de interne onderdelen van het apparaat aangeraakt mogen worden.



Persoonlijke beschermingsmiddelen dienen tijdens het onderhoud correct gebruikt te worden.



Lees de installatiehandleiding



Lees de instructies

■ Condizioni di manutenzione

Le manutenzioni devono essere fatte da un tecnico specializzato e attenendosi alla normativa in vigore nel paese di installazione.



Qualsiasi modifica o intervento sul dispositivo non autorizzato dal fabbricante causerà sistematicamente la cancellazione della garanzia.



Prima di qualunque intervento, assicurarsi di avere interrotto l'alimentazione elettrica generale.



Energia immagazzinata: dopo aver interrotto l'alimentazione aspettare 10 minuti prima di accedere alle parti interne dell'apparecchio.



I dispositivi di protezione individuale devono essere correttamente utilizzati.



Leggere il manuale d'installazione



Leggere le istruzioni

■ Condiciones para el mantenimiento

La bomba de calor debe ser mantenida por un profesional cualificado de acuerdo con la normativa vigente y las prescripciones del manual técnico.



Cualquier modificación o intervención en el dispositivo no autorizada por el fabricante anulará automáticamente la garantía.



Antes de llevar a cabo cualquier intervención compruebe que el suministro general de corriente está cortado.

Energía acumulada: después de interrumpir la alimentación espere 10 minutos antes de acceder a las partes internas del equipo.



El equipo de protección individual esté se use adecuadamente.



Leer el manual de instalación



Leer las instrucciones

■ Condições de manutenção

A manutenção do equipamento devem ser efetuadas por um profissional autorizado de acordo com os textos regulamentares e regras da arte em vigor.



Qualquer modificação ou intervenção no aparelho não autorizada pelo fabricante provocará sistematicamente uma supressão da garantia.



Antes de proceder a qualquer intervenção, verifique se todas as fontes de alimentação elétrica estão cortadas.

Energia acumulada: depois de desligar a alimentação elétrica aguardar 10 minutos antes de aceder aos componentes internos do equipamento.



Os equipamentos de proteção individual estão são usados corretamente.



Leer o manual de instalação



Leer as instruções

■ Przepisy dotyczące konserwacji

Konserwacja urządzenia muszą być wykonywane przez uprawnionego instalatora zgodnie z obowiązującymi przepisami oraz zasadami sztuki.



Wszelkie modyfikacje lub przeróbki urządzenia nieautoryzowane przez producenta powodują automatyczne unieważnienie gwarancji.



Przed rozpoczęciem wszelkich czynności sprawdzić, czy wszystkie zasilania elektryczne są odcięte.

Zgromadzona energia: po odłączeniu zasilania elektrycznego odczekać 10 minut przed przystąpieniem do prac przy wewnętrznych elementach urządzenia.



Środki ochrony indywidualnej są one prawidłowo używane.



Przeczytać instrukcję instalacji



Przeczytać instrukcje

■ Üldised hooldustingimused

Seadet võib hooldada vastava kvalifikatsiooniga erialaspetsialist vastavalt kehtivatele õigusaktidele ja valdkonnas kehtivatele eeskirjadele.



Seadme mis tahes viisil muutmine või selle töösse sekkumine ilma tootja loata muudab seadme garantii automaatselt kehtetuks.



Enne kõiki töid veenduge, et elektritoide on lahti ühendatud.

Salvestatud energia: pärast toitejuhtme vooluvõrgust eemaldamist oodake 10 minutit enne seadme sees asuvate detailidele juurdepääsemist.



Individuaalsed kaitsevahendid kasutatakse nõuetekohaselt.



Lugege paigaldusjuhendit



Lugege juhiseid

■ **Předpisy týkající se údržby**

Údržba zařízení musejí být prováděny prostřednictvím autorizovaného pracovníka v souladu s platnými předpisy a odborovými pravidly.



Jakékoli zásahy nebo úpravy prováděné na zařízení bez svolení výrobce automaticky zruší platnost záruky.



Před jakýmkoli zásahem ověřte, zda jsou odpojena všechna elektrická napájení.

Uskladněná energie: po odpojení napájení počkejte 10 minut, než začnete pracovat na vnitřních součástech zařízení.



Osobní ochranné prostředky jsou používány správně.



Přečtěte si návod k instalaci



Přečtěte si návod

■ **Priežiūros sąlygos**

Priežiūrą turi atlikti patvirtintas specialistas pagal galiojančius teisės aktus ir taisykles.



Be gamintojo leidimo pakeitus prietaisą ar atlikus su juo kokius nors veiksmus, be išimčių atšaukiama gaminio garantija.



Prieš imdamiesi bet kokių intervencinių veiksmų, įsitinkinkite, kad nutrauktas visas elektros tiekimas.

Sukaupta energija: atjungę maitinimo šaltinius, prieš bandydami pasiekti vidines įrangos dalis, palaukite 10 minučių.



Asmeninės apsaugos priemonės yra tinkamai naudojamos.



Žr. montavimo instrukciją



Žr. instrukcijas

SL

■ Pogoji za vzdrževanje

Napravo mora vzdrževati pooblaščen strokovnjak v skladu z veljavnimi predpisi in pravili.



Garancija se bo samodejno razveljavila v primeru kakršne koli spremembe ali posega v napravo, ki ju ni odobril proizvajalec.



Pred vsakim posegom preverite, ali je odklopljeno celotno električno napajanje.

Shranjena energija: po odklopu napajanja počakajte 10 minut preden posežete v notranjost naprave.



Osebna zaščitna oprema je na je pravilno uporabljena.



Preberite navodila za namestitev



Preberite navodila

EL

■ Όροι συντήρησης

Η συντήρηση της συσκευής πρέπει να γίνεται από εξουσιοδοτημένο επαγγελματία, σύμφωνα με τους ισχύοντες κανονισμούς και ειδικούς κανόνες.



Τυχόν μη εξουσιοδοτημένη από τον κατασκευαστή τροποποίηση ή παρέμβαση στη συσκευή θα ακυρώσει αυτόματα την εγγύηση.



Πριν από οποιαδήποτε παρέμβαση, βεβαιωθείτε ότι έχουν διακοπεί όλες οι ηλεκτρικές παροχές.

Αποθηκευμένη ενέργεια: μετά την αποσύνδεση των τροφοδοτικών περιμένετε 10 λεπτά πριν από την πρόσβαση στα εσωτερικά μέρη του εξοπλισμού.



Τα μέσα ατομικής προστασίας είναι χρησιμοποιούνται σωστά.



Διαβάστε τις οδηγίες εγκατάστασης



Διαβάστε τις οδηγίες

■ Uslovi održavanja

Održavanje uređaja mora izvesti ovlašćeni stručnjak u skladu s važećim regulativama i pravilima.



Svaka izmena ili intervencija na aparatu koja je neovlašćena od strane proizvođača sistematski dovodi do poništenja garancije.



Pre bilo kakve intervencije proverite jesu li isključeni svi izvori električne energije.

Zaostala energija: nakon isključivanja napajanja sačekajte 10 minuta pre pristupa unutrašnjim delovima opreme.



Lična zaštitna oprema pravilno se koristi.



Pročitajte uputstva za instalaciju



Pročitajte uputstva

■ Säännönmukaiset huolto-ohjeet

Laitteen huolto on suoritettava valtuutetun ammattihenkilön toimesta säännönmukaisten tekstien ja voimassa olevien sääntöjen mukaisesti.



Kaikki muut kuin valmistajan sallimat laitteelle tehdyt muokkaukset tai toimenpiteet aiheuttavat systemaattisesti takuun peruuttamisen.



Varmista ennen toimenpiteiden suorittamista, että virransyöttö on katkaistu.

Tallennettu energia: virransyötön katkaisemisen jälkeen odota 10 minuuttia ennen laitteen sisäosiin koskemista.



Personal protective equipment is being used correctly



Lue asennusohjeet



Lue ohjeet

■ Regler och villkor för underhåll

Underhållet av enheten måste utföras av en godkänd installatör i enlighet med gällande föreskrifter och regler.



Alla ändringar eller ingrepp på enheten som inte godkänts av tillverkaren upphäver automatiskt garantin.



Innan eventuellt ingripande ska du se till att alla elektriska tillbehör är avstängda.

Lagrad energi: efter att strömförsörjningen brutits vänta 10 minuter innan du ingriper på utrustningens inre delar.



Personlig skyddsutrustning finns används korrekt.



Läs installationsanvisningarna



Läs instruktionerna

■ Podmienky pre údržbu

Údržbu zariadenia musí vykonávať odborník s povolením v súlade s platnými predpismi a súčasným stavom techniky.



Akékoľvek úpravy alebo zásahy na zariadení, ktoré neschválil výrobca, automaticky zrušia záruku.



Pred akýmkoľvek zásahom sa uistíte, že sú zo siete odpojené všetky elektrické zdroje.

Uložená energia: po odpojení napájacích zdrojov počkajte 10 minút pred prístupom k vnútorným častiam zariadenia.



Osobné ochranné prostriedky sú správne používané.



Prečítajte si návod na inštaláciu



Prečítajte si inštrukcie

■ Betingelser for vedligeholdelse

Vedligeholdelsen af apparatet skal udføres af en professionel godkendt installatør i henhold til de gældende bestemmelser og fagets metoder.



Enhver ændring eller indgreb i enheden, som ikke er godkendt af producenten, vil systematisk medføre, at garantien bortfalder.



Sørg for, at al el-forsyning er afbrudt, inden arbejdet påbegyndes.

Lagret energi: Efter frakobling af el-forsyningen skal du vente 10 minutter, før du rører udstyrets interne dele.



Personlige værnemidler er korrekt anvendt.



Læs installationsvejledningen



Læs instruktionerne

■ Karbantartási előírások

A berendezés karbantartását szerződéses szakembernek kell végeznie az érvényben lévő jogszabályi és szakmai előírásoknak megfelelően.



A készüléken végzett minden engedély nélküli módosítás vagy beavatkozás automatikusan érvényteleníti a garanciát.



Minden beavatkozás előtt ellenőrizze, hogy az összes elektromos tápellátás le van csatlakoztatva.

Tárolt energia: az áramellátás szakaszolását követően várjon 10 percet mielőtt a berendezés belső alkatrészeihez hozzáférne.



Egyéni védőfelszerelés megfelelően használva van.



Olvassa el a telepítési utasítást



Olvassa el az utasításokat

NO

■ Forskriftsmessige for vedlikehold

Vedlikehold av utstyret må utføres av en sertifisert fagperson i samsvar med gjeldende forskrifter og regler på området.



Alle endringer eller inngrep på apparatet som produsenten ikke har tillatt, fører automatisk til at garantien bortfaller.



Før ethvert arbeid utføres, sørg for at alle strømkilder er brutt.

Lagret energi: etter å ha brutt strømmen, vent i 10 minutter før det gis adgang til utstyrets interne deler.



Personlig beskyttelsesutstyr skal være brukt riktig.



Les installasjonsanvisningen



Les instruksjonene

HR

■ Zakonski uvjeti održavanja

Održavanje uređaja mora vršiti ovlašteni operator u skladu s propisima i pravilima na snazi.



Svaka preinaka ili intervencija na uređaju koje nije odobrio proizvođač ima za posljedicu sustavni gubitak jamstva.



Prije svake intervencije, provjerite jesu li sva električna napajanja isključena.

Uskladištena energija: nakon isključenja svih napajanja, pričekajte 10 minuta prije nego što pristupite unutarnjim dijelovima opreme.



Osobna zaštitna oprema je propisno korištena.



Pročitajte upute za instaliranje



Pročitajte upute

■ **Условия за поддръжка**

Поддръжката на устройството трябва да се извърши от одобрен специалист в съответствие с действащите нормативни текстове и технически изисквания.



Всяка модификация или интервенция върху устройството, която не е разрешена от производителя, систематично води до анулиране на гаранцията.



Преди всяка операция се уверете, че всички електрически захранвания са прекъснати.



Съхранена енергия: след изключване на захранването изчакайте 10 минути преди да работите по вътрешните части на оборудването.



Лични предпазни средства са използват правилно.



Прочетете инструкциите за монтаж



Прочетете инструкциите

■ **Bakım koşulları**

Cihazın bakımı, yönetmeliksel belgelere ve yürürlükteki kurallara uygun olarak bir profesyonel tarafından gerçekleştirilmelidir.



Cihaz üzerinde üretici tarafından izin verilmeyen herhangi bir değişiklik veya müdahale otomatik olarak garantiyi geçersiz kılacaktır.



Her tür müdahaleden önce, tüm elektrik bağlantılarının kesildiğinden emin olun.



Depolanmış enerji: Güç kaynaklarını ayırdıktan sonra, ekipmanların iç kısımlarına erişmeden önce 10 dakika bekleyin.



Kişisel koruma ekipmanları doğru şekilde kullanılmalıdır.



Kurulum talimatını okuyun



Talimatları okuyun

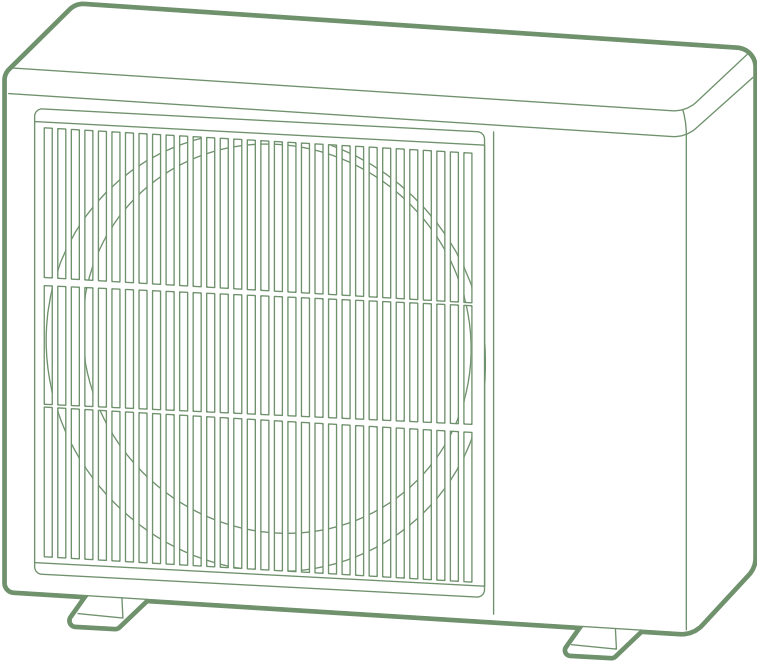

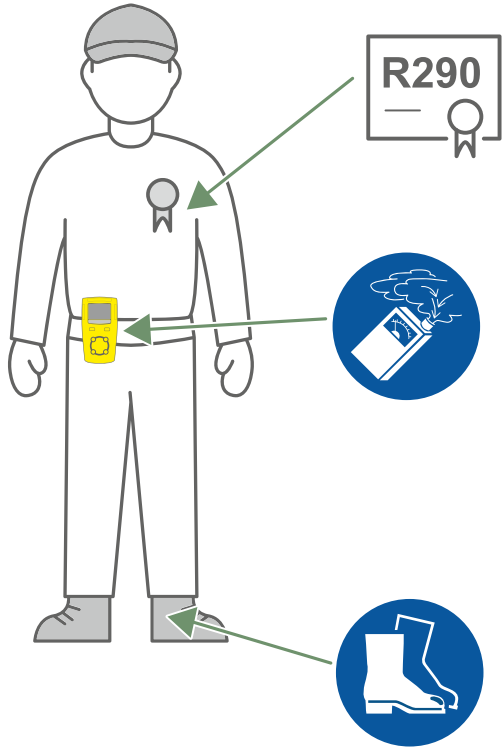

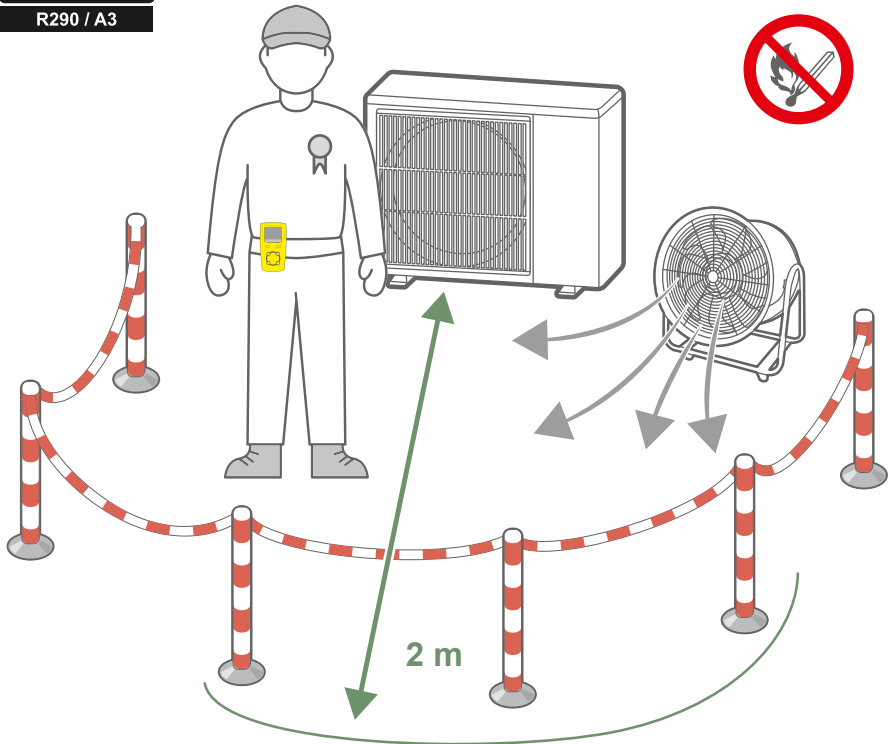

1

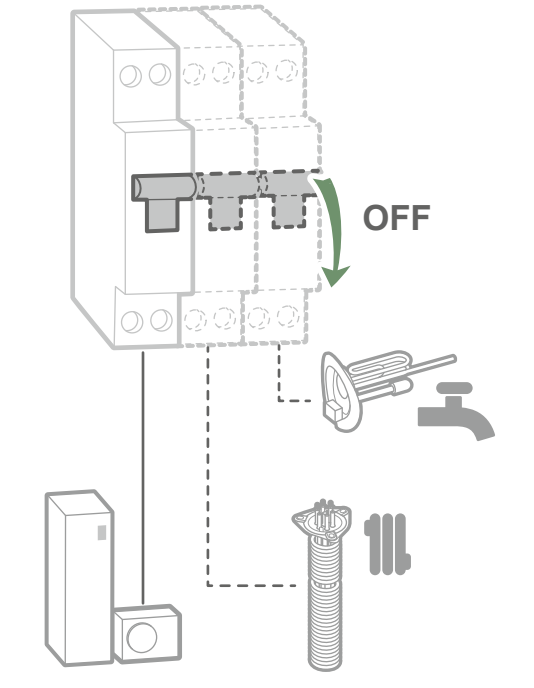
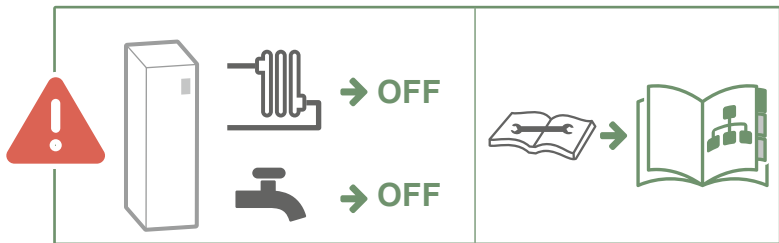

2

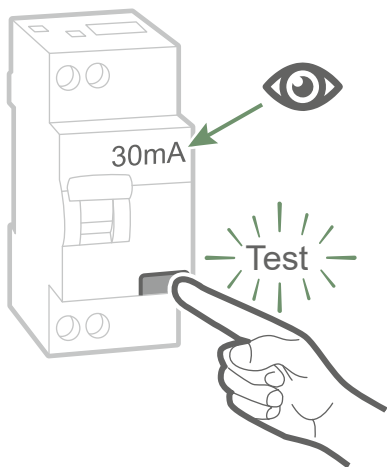

3

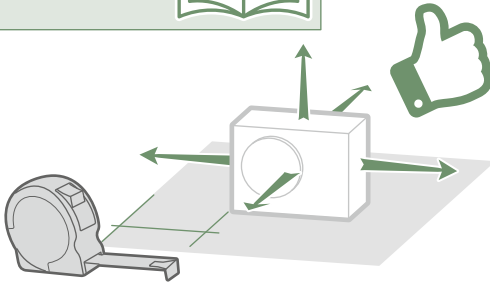

4

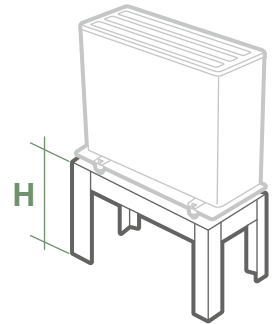
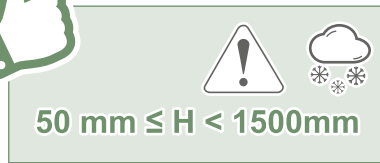
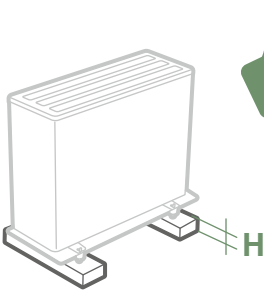

5

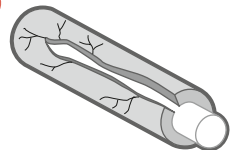
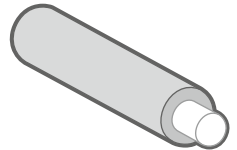
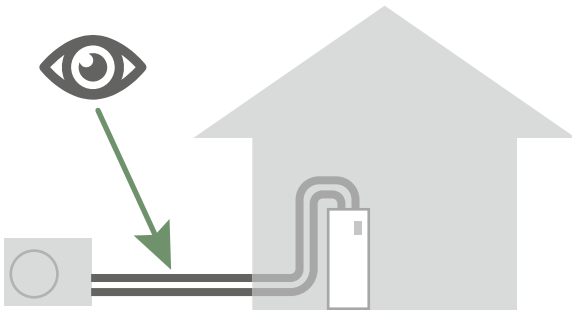

6

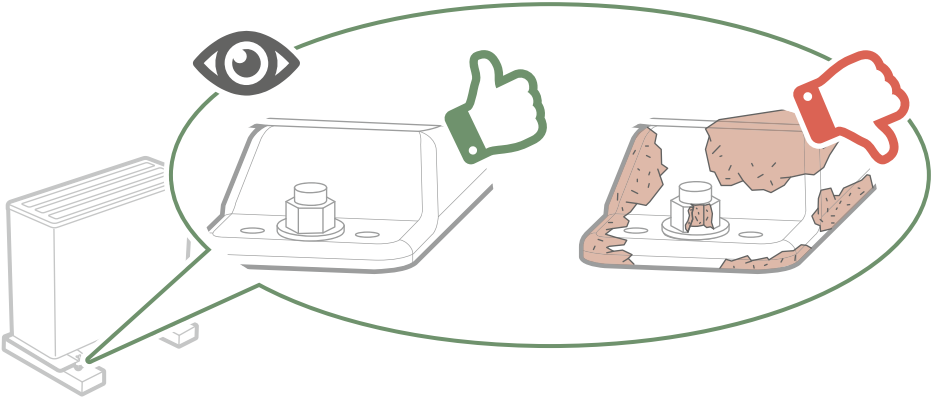

7

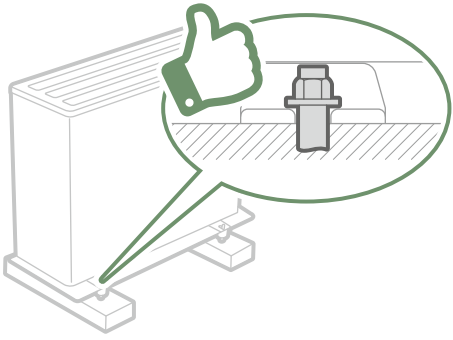

8

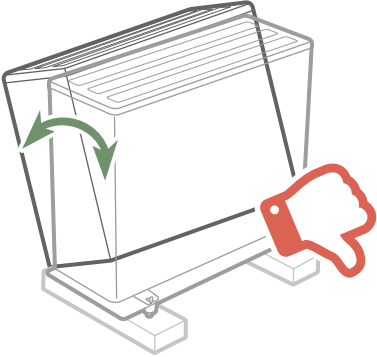

9

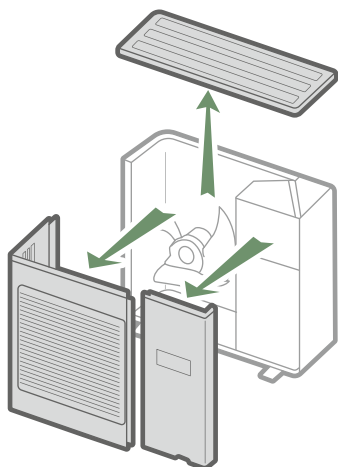

10

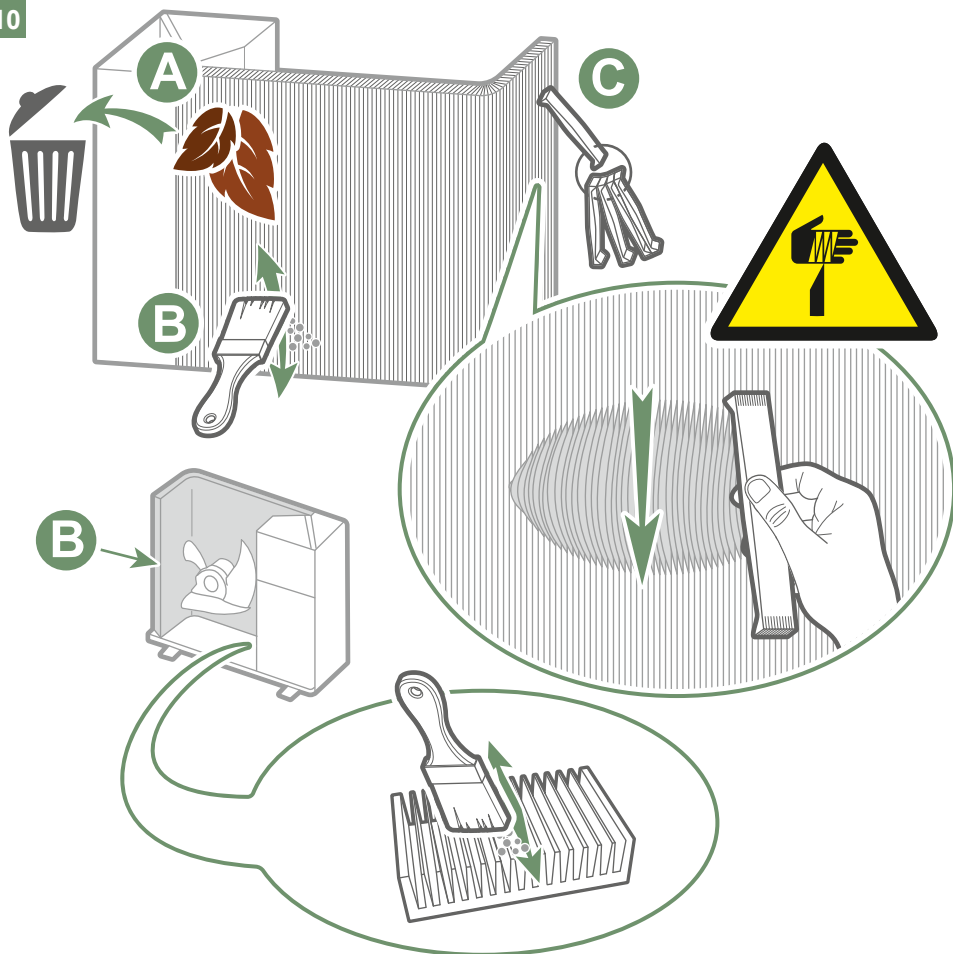

11

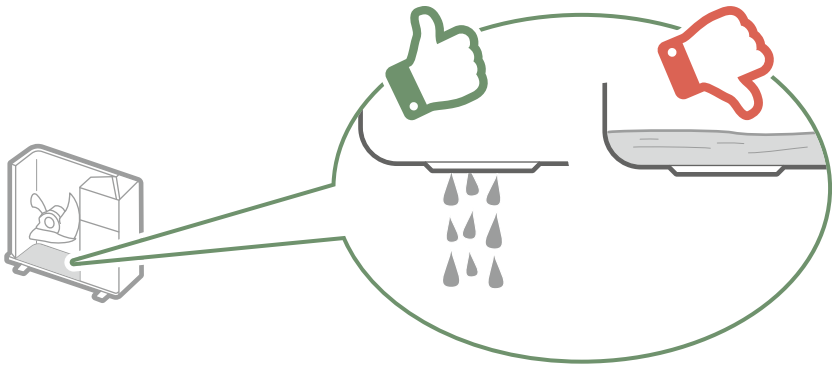

12

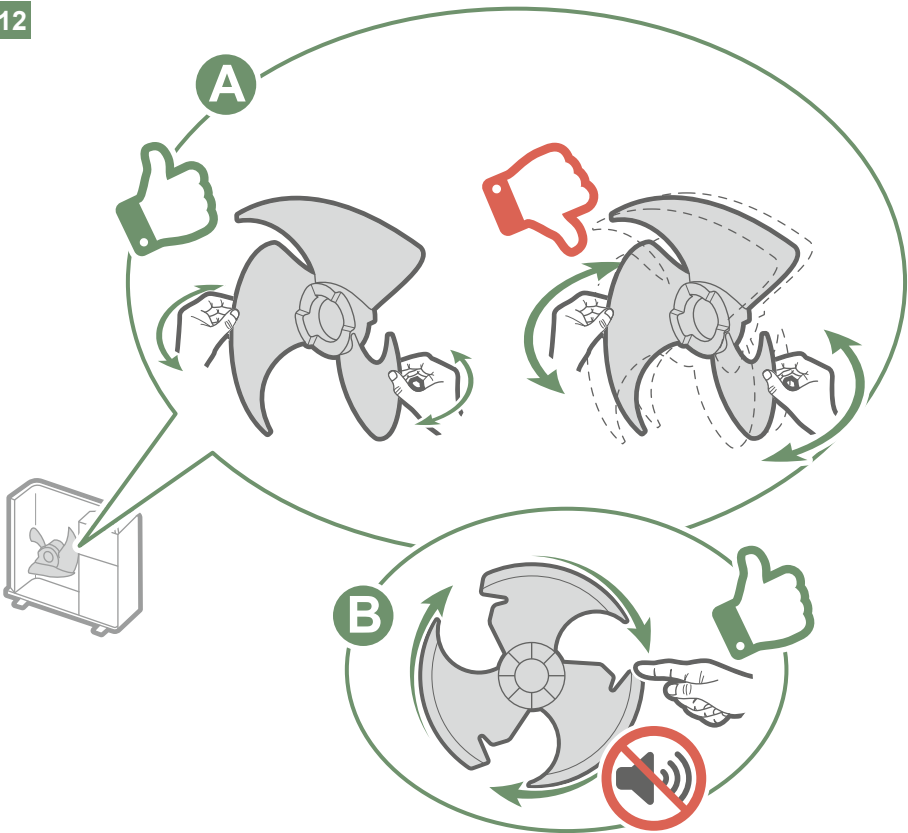

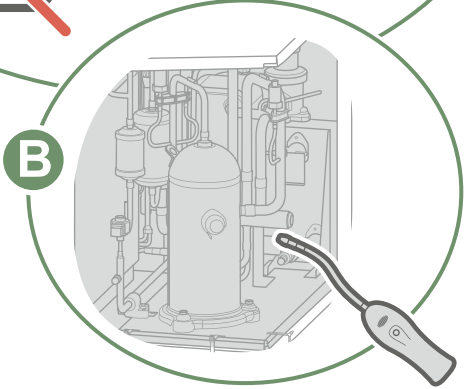
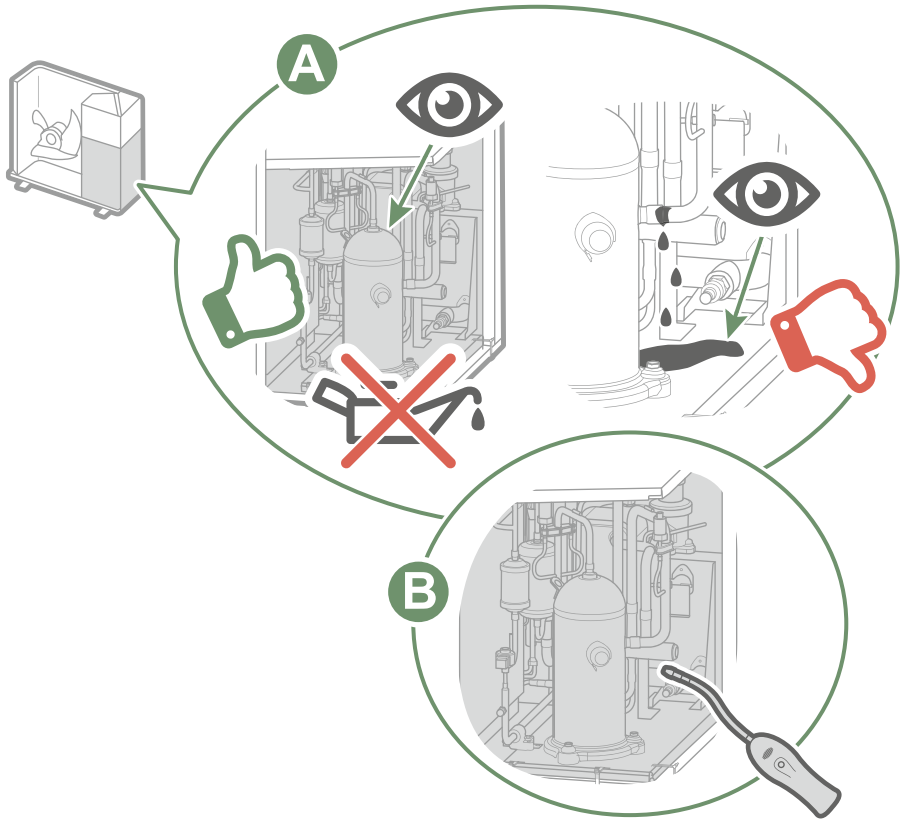

15

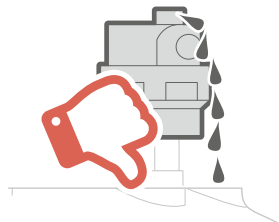
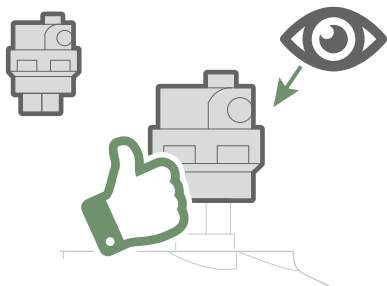

16

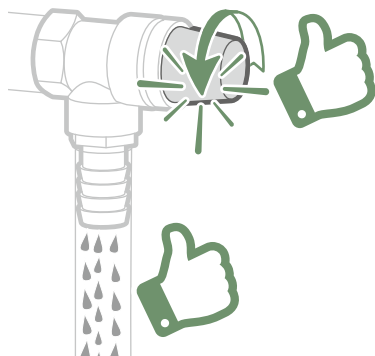

17

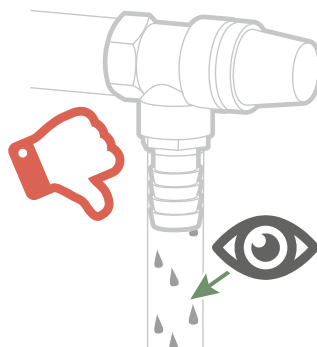
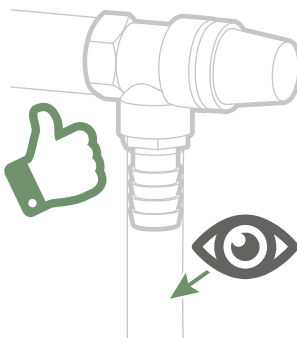

18

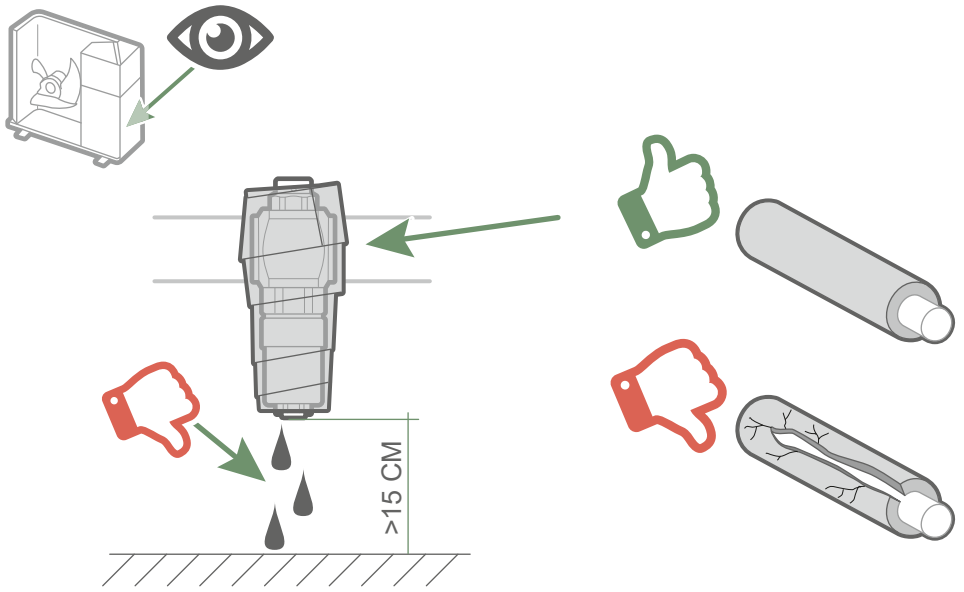

19

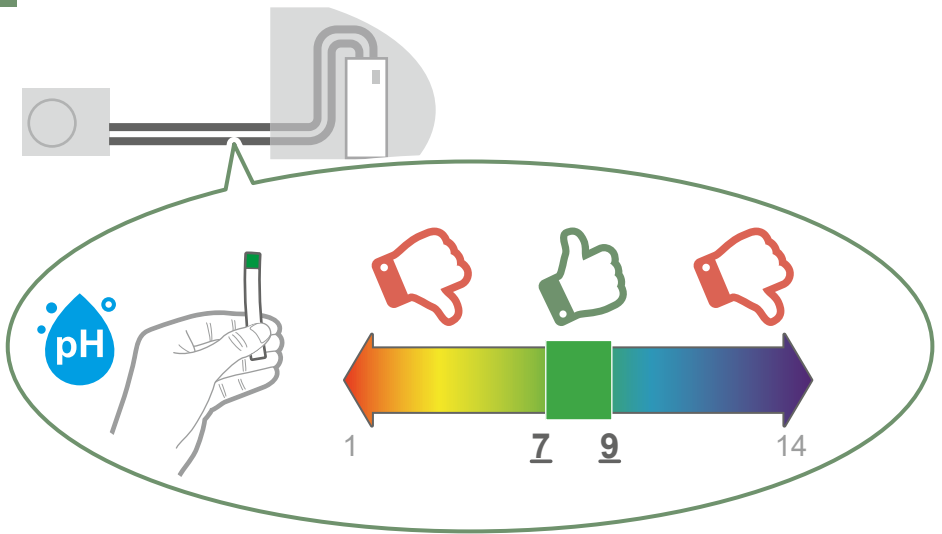

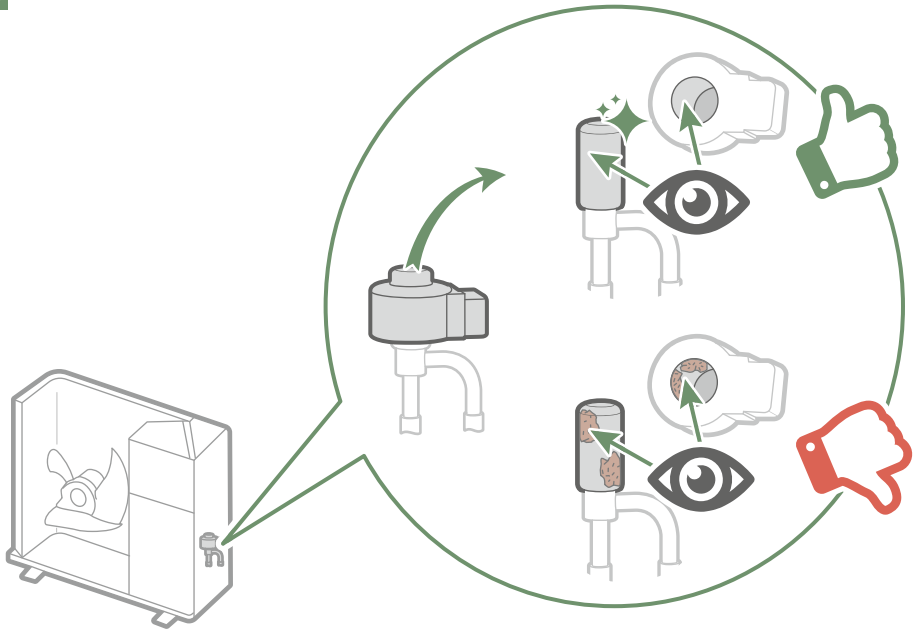

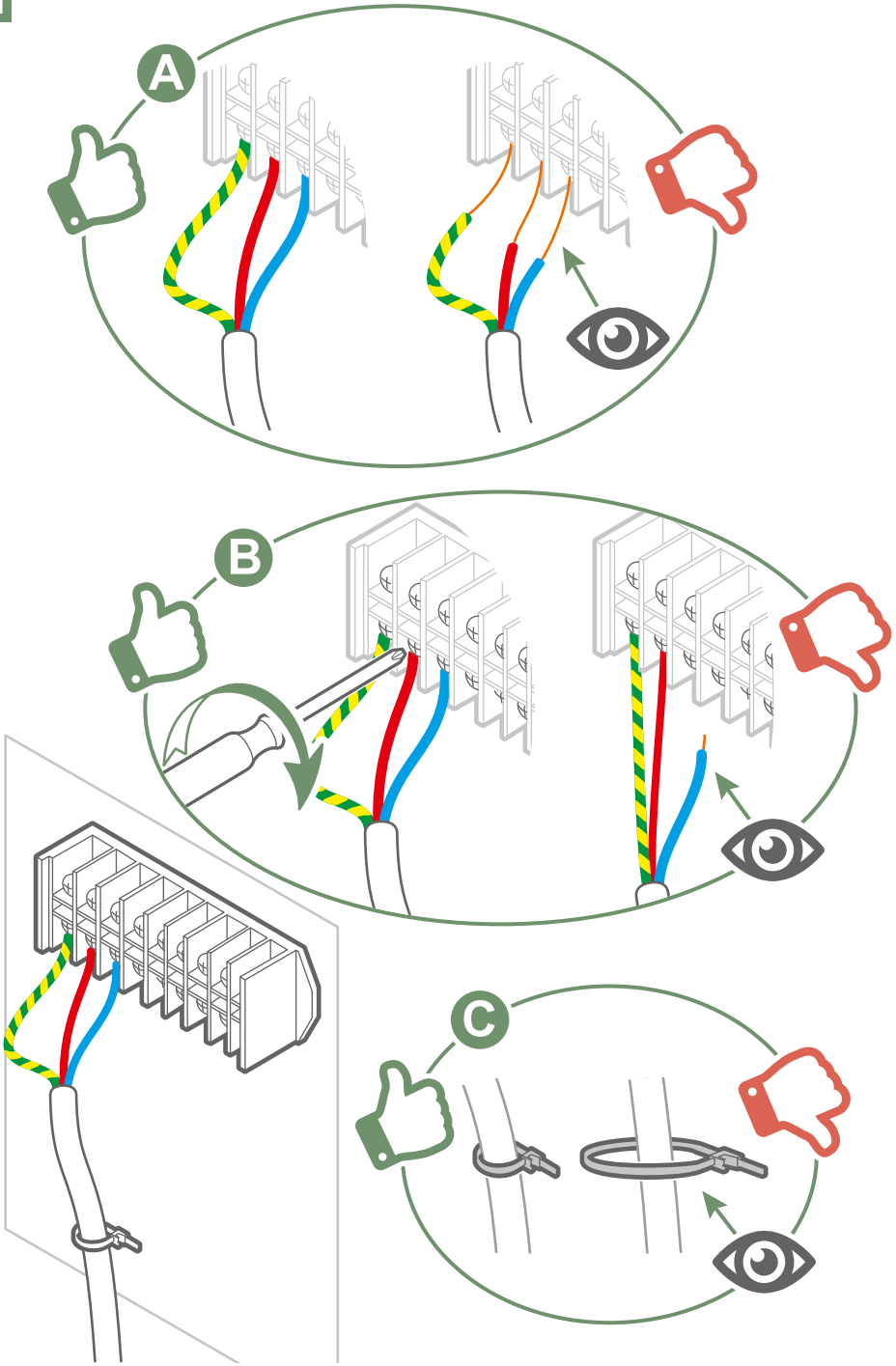

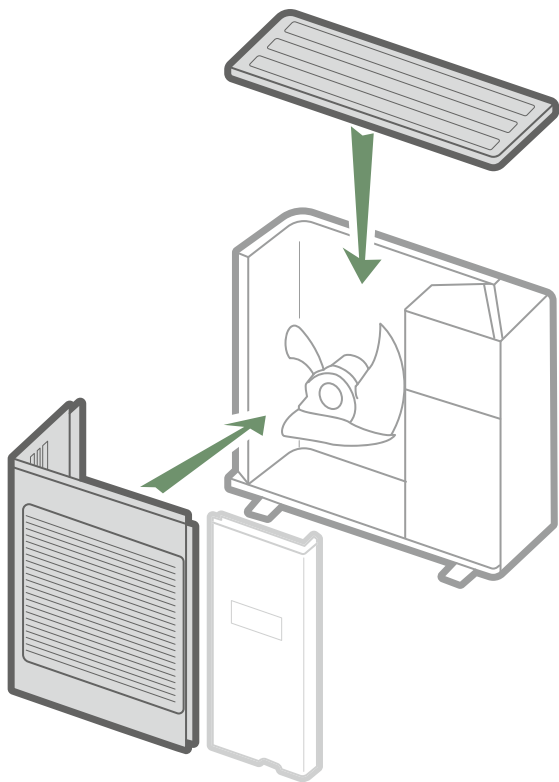

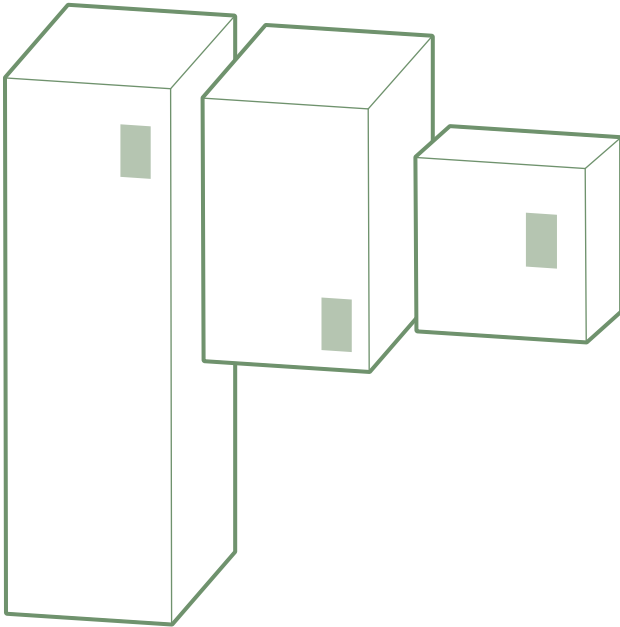

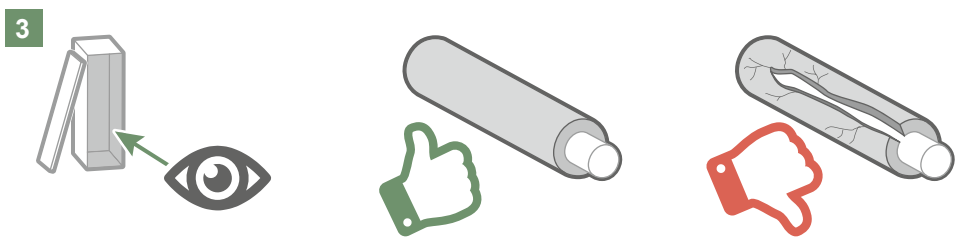
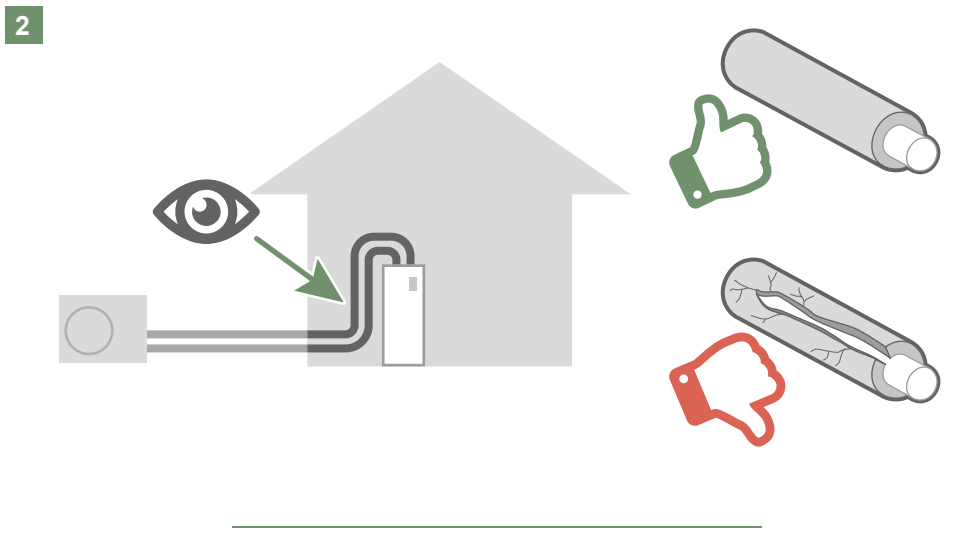
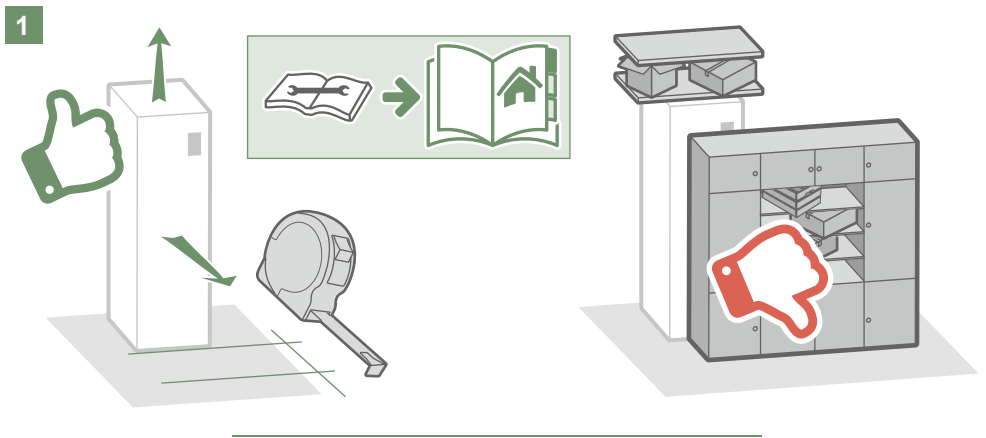

4

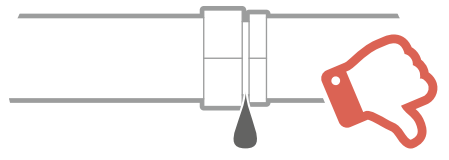
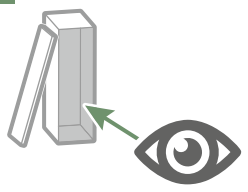

5

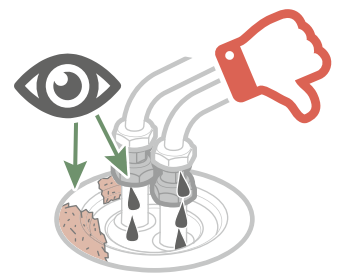
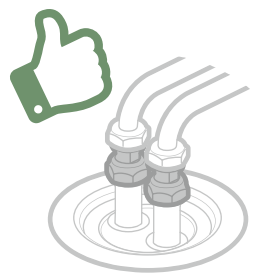
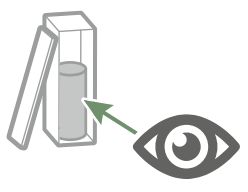

6

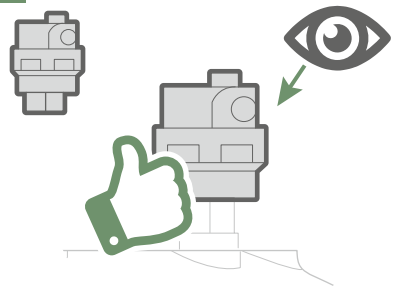

7

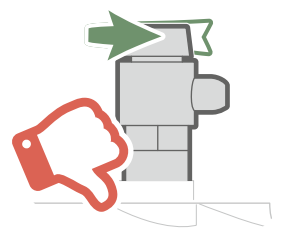
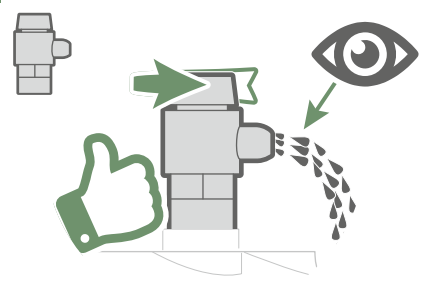

8

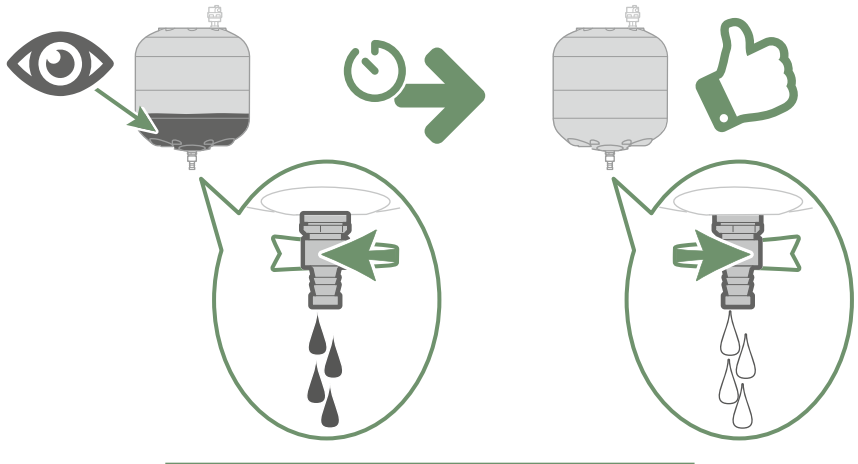

9

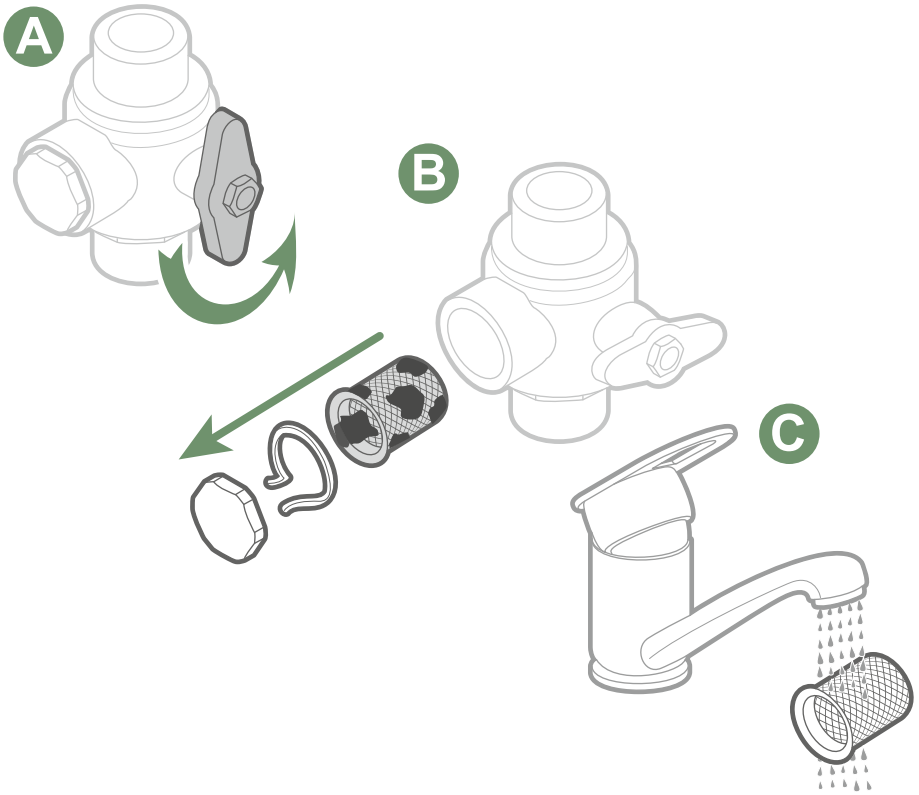

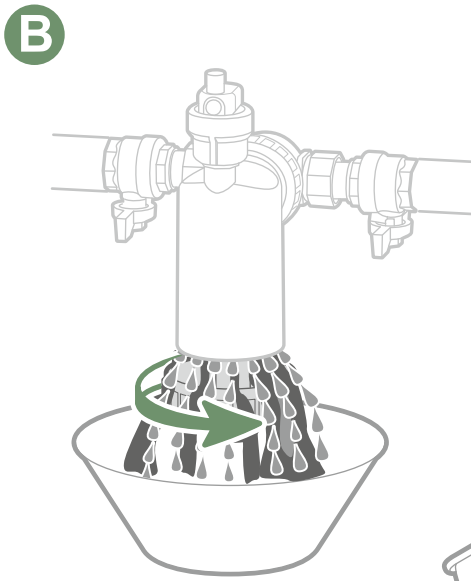
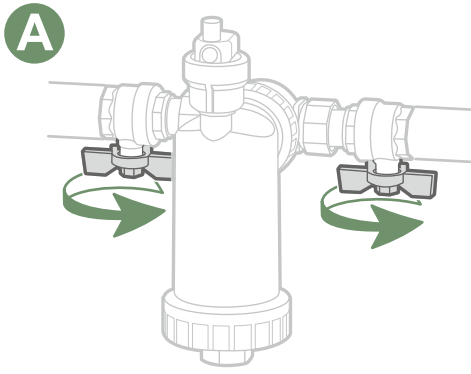

11

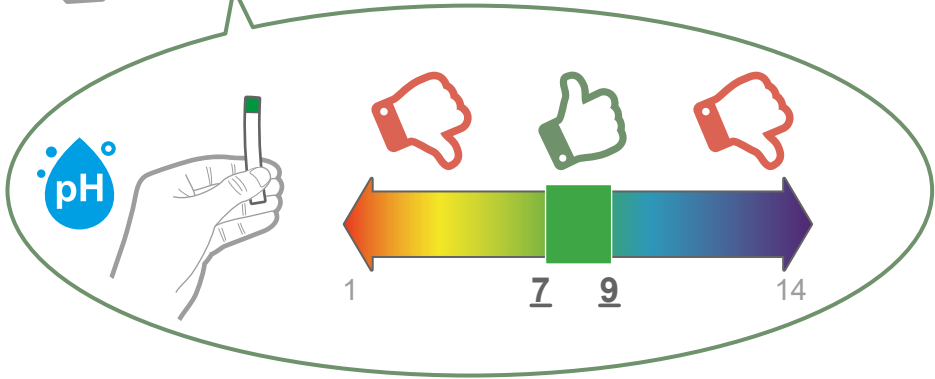

12

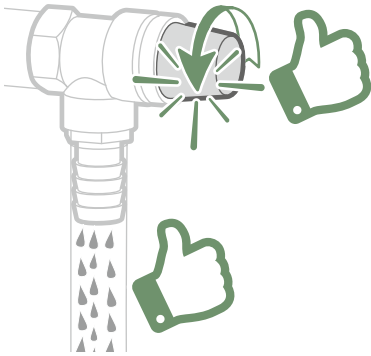

13

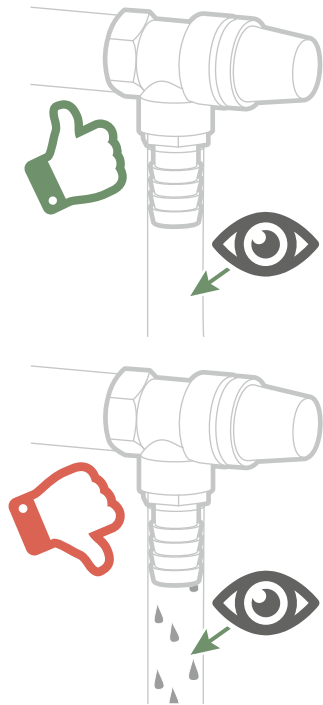

14

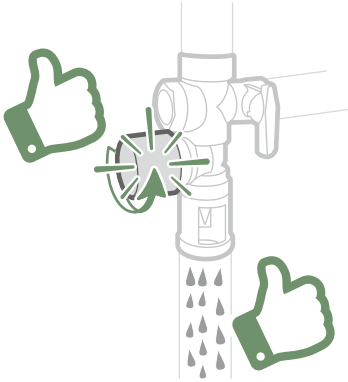

15

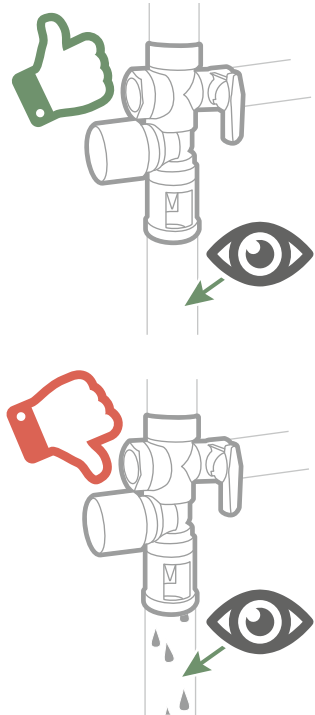

16



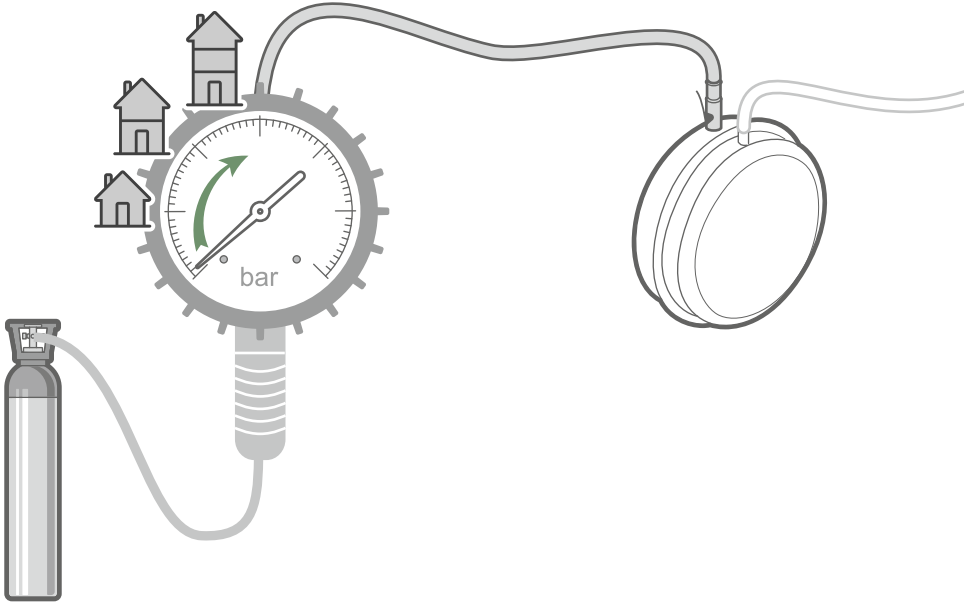
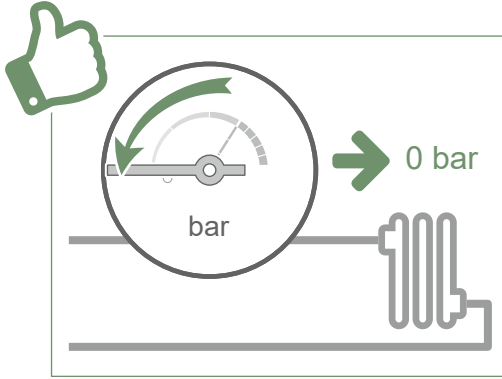

18

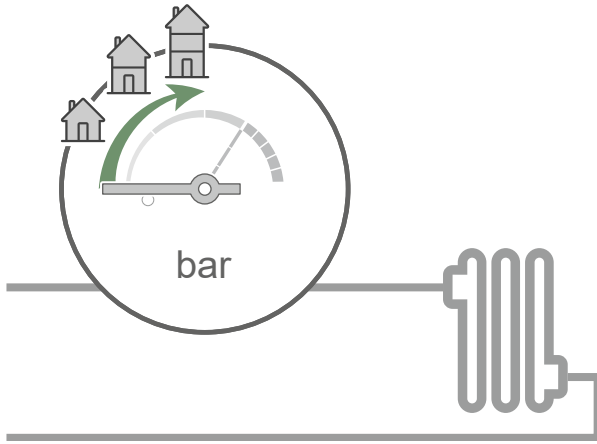

19



20

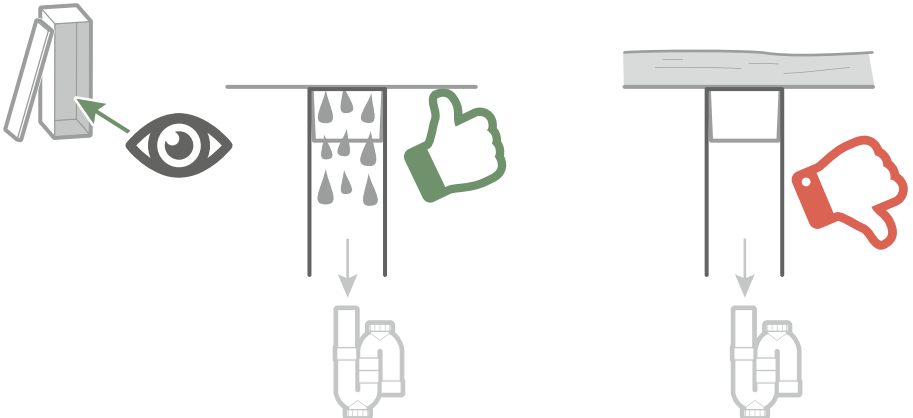

A

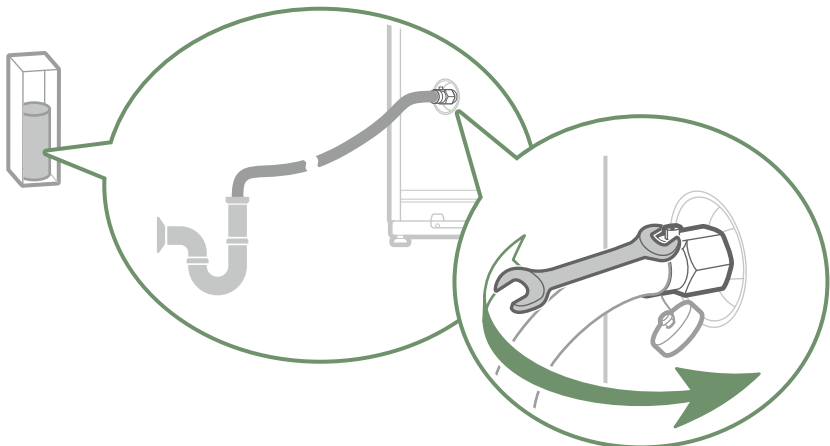

B

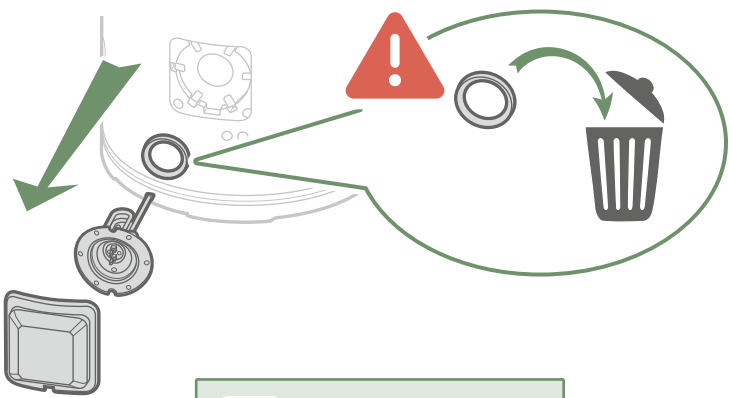

ACI → D

C

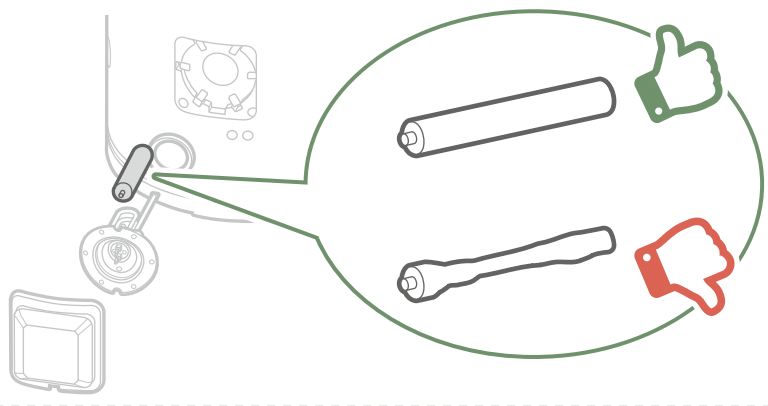

D

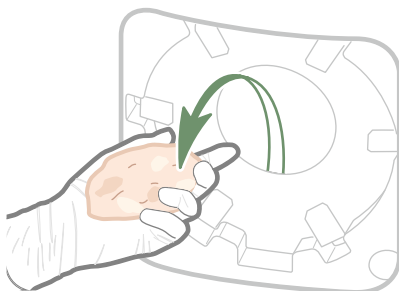

E

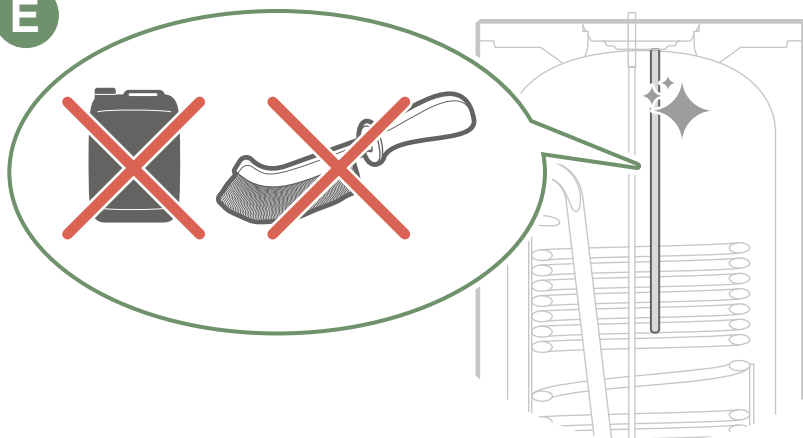

F

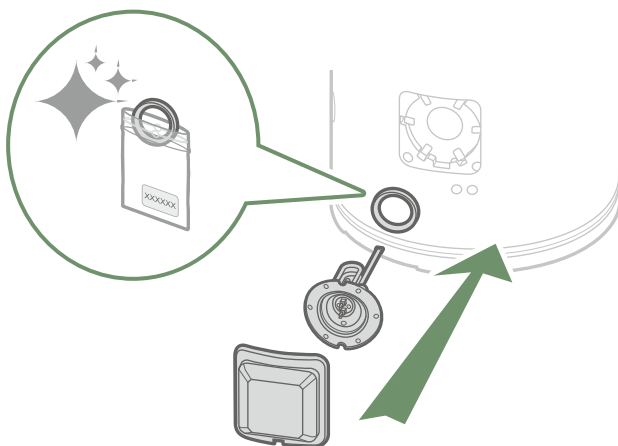

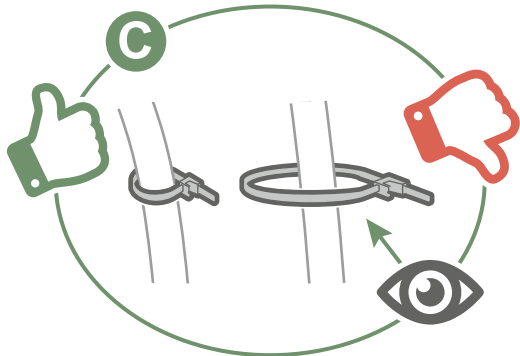
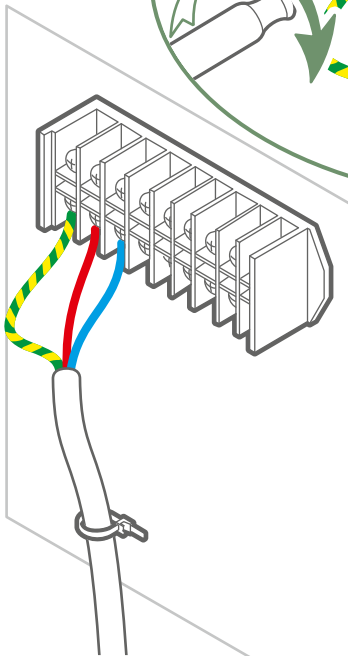
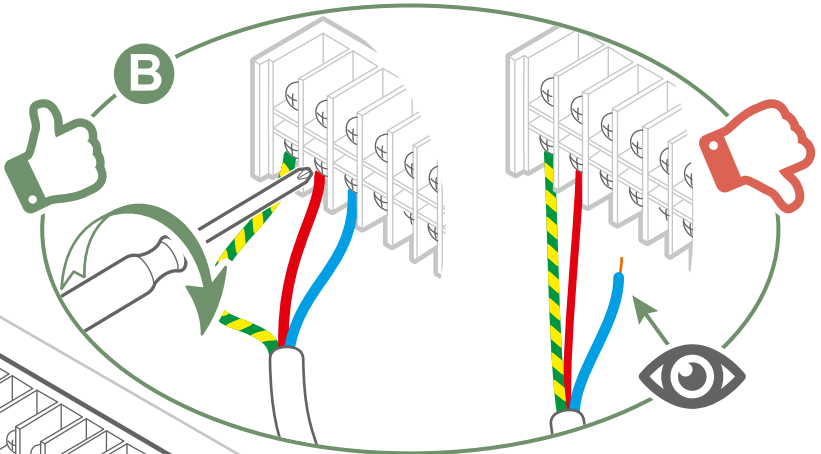
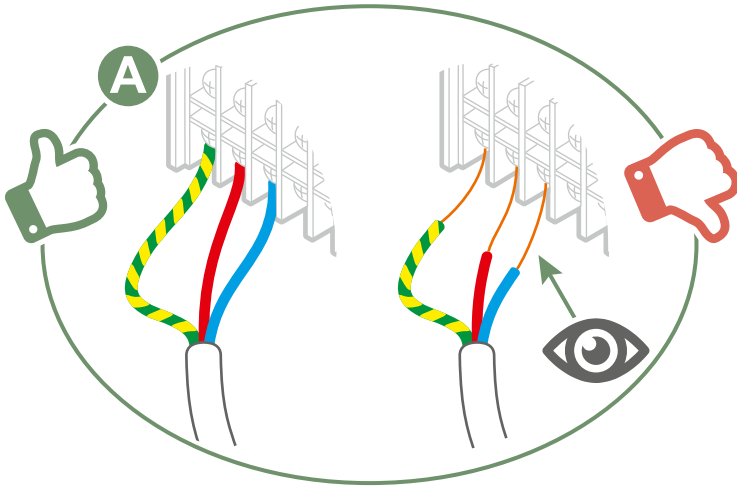

23

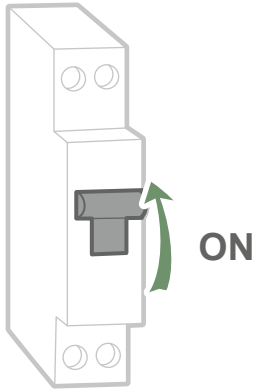

24

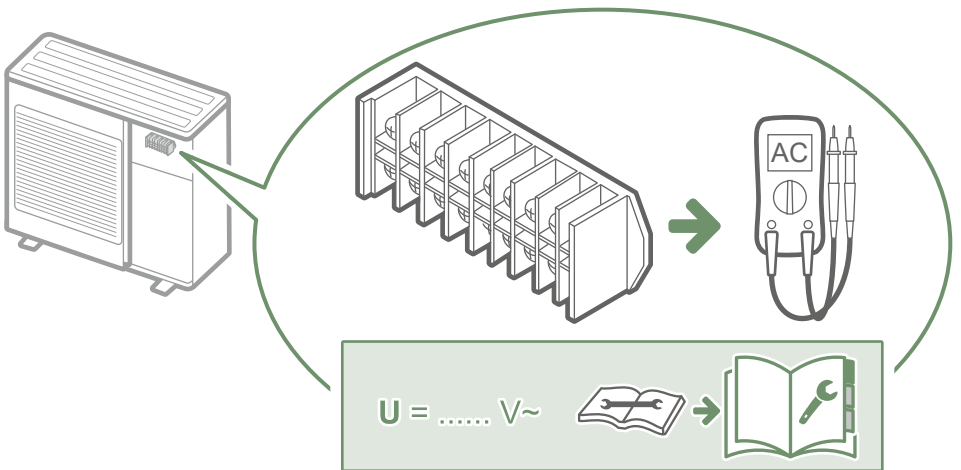

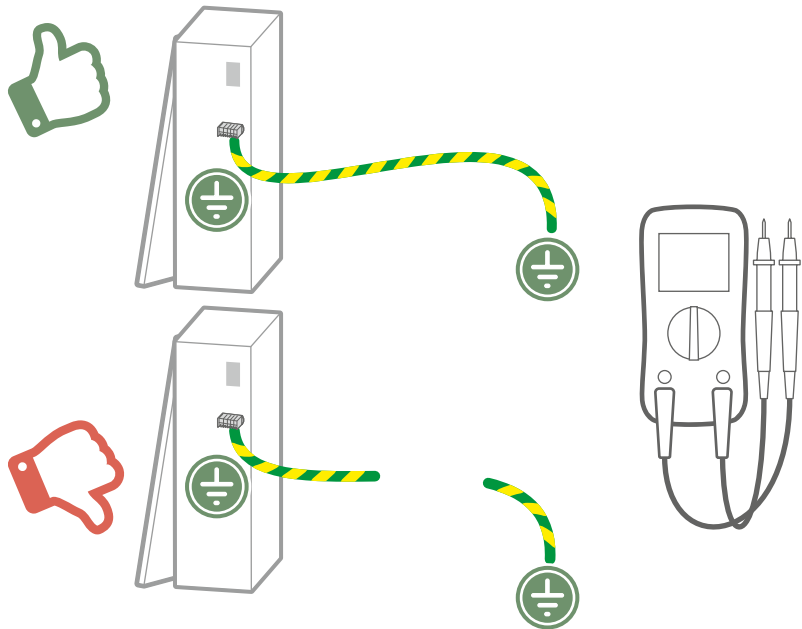
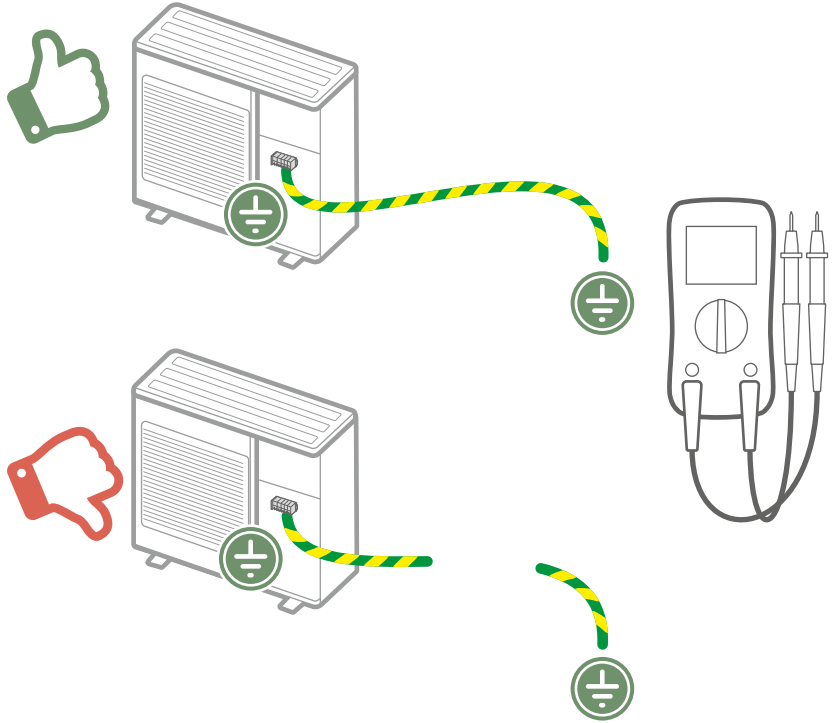

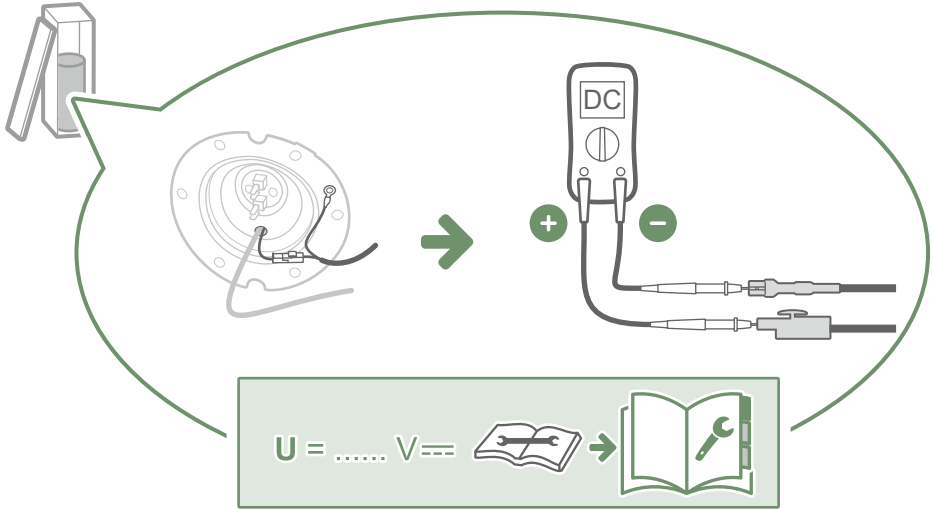





TEST



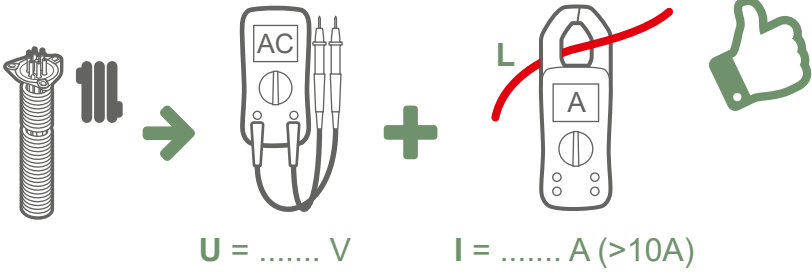

28



$U \times I = \dots\dots W$



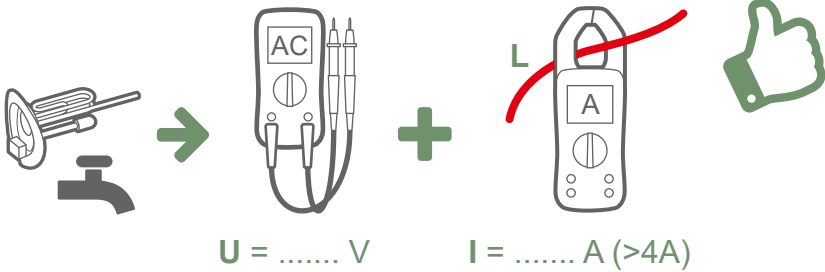

29



$U \times I = \dots\dots W$



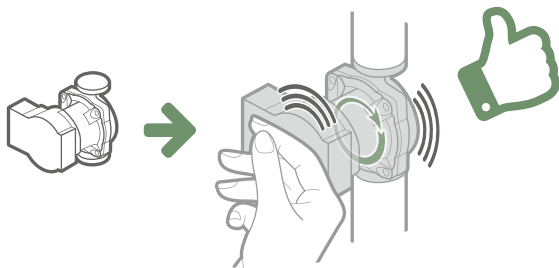

30

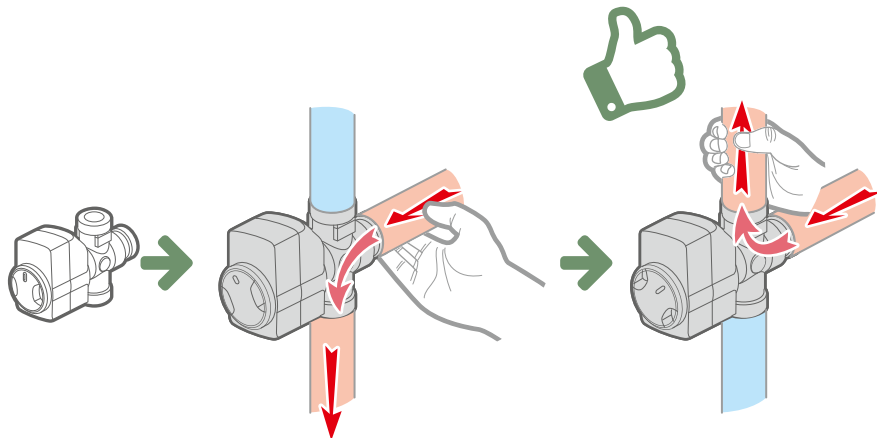

31

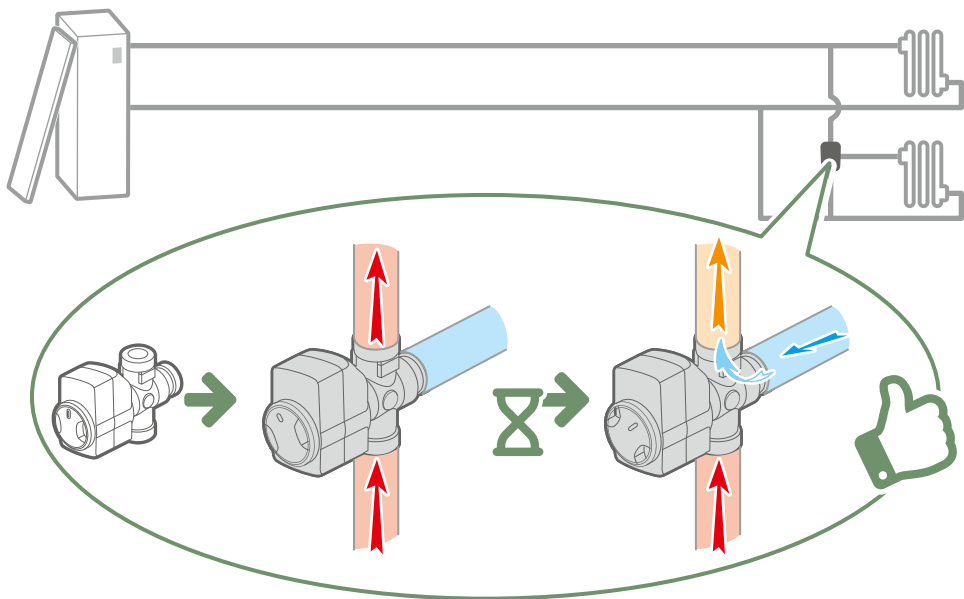

32



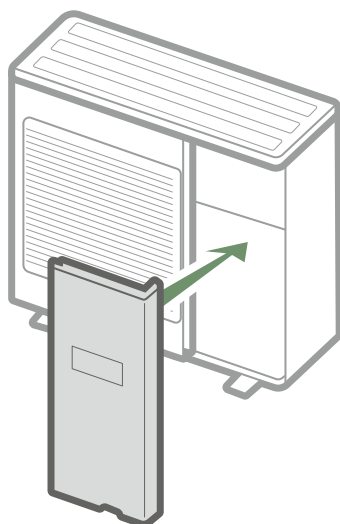
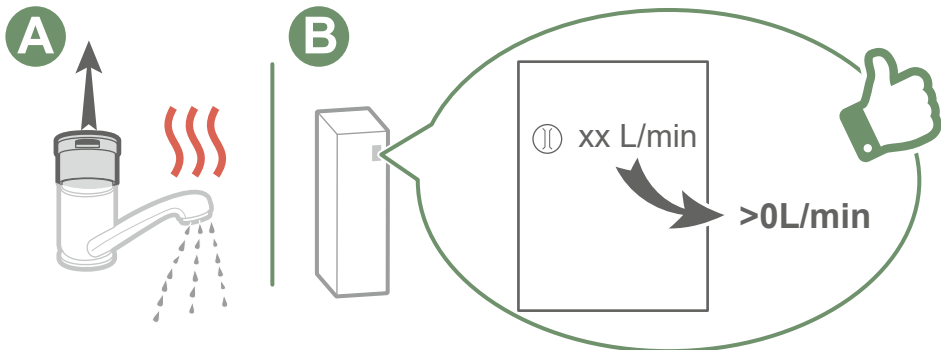

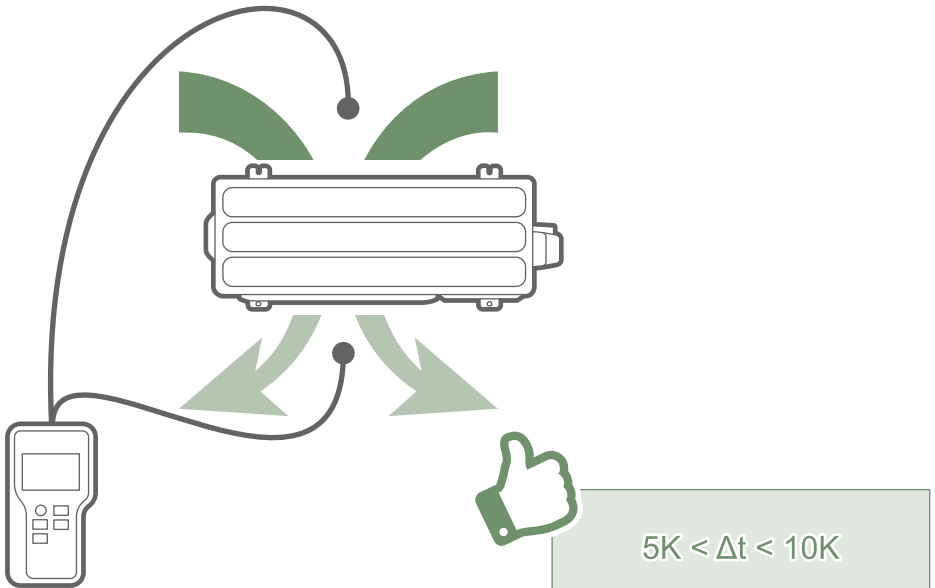
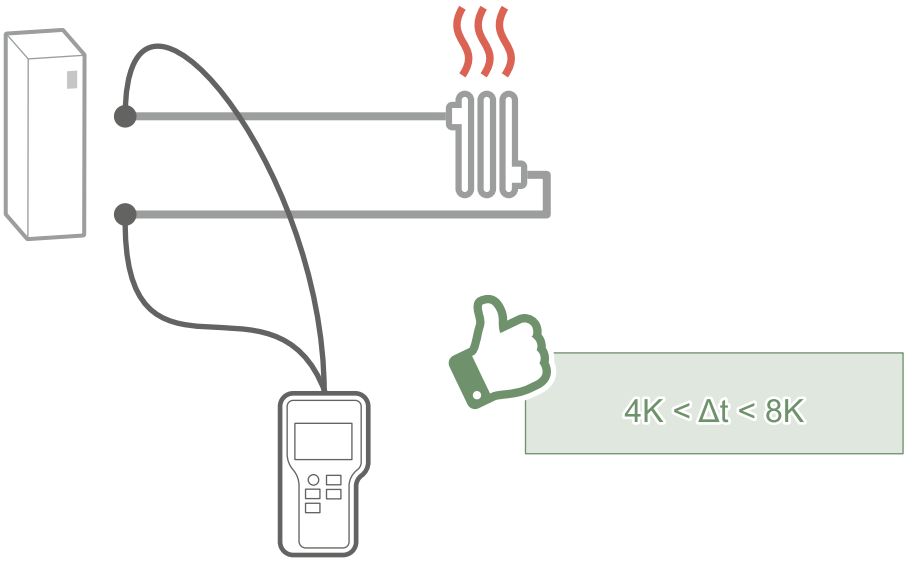



AMBB
SATC - rue des fondeurs
59660 MERVILLE - France
www.atlantic.fr
atlantic-comfort.com